



# 1

## Firestone TPO Roofing Systems

To ensure a long-lasting, trouble-free roof today, it is not sufficient to manufacture high quality roofing membranes. Experience learned that roofing membranes need to be compatible with other products in order to be integrated into a complete waterproofing system, which will function under extremely variable conditions.

Depending upon these conditions, the specifier can select one of the following roofing systems:

- 1 Ballasted System . . . . . p. 1. 3
- 2 Inverted System . . . . . p. 1. 4
- 3 Mechanically Attached System . . . . . p. 1. 5
- 4 Fully Adhered System . . . . . P. 1. 6

In the following pages you will find a brief description and illustration of each individual Firestone TPO Roofing System, including its main characteristics and advantages.





## 1.1 Ballasted System

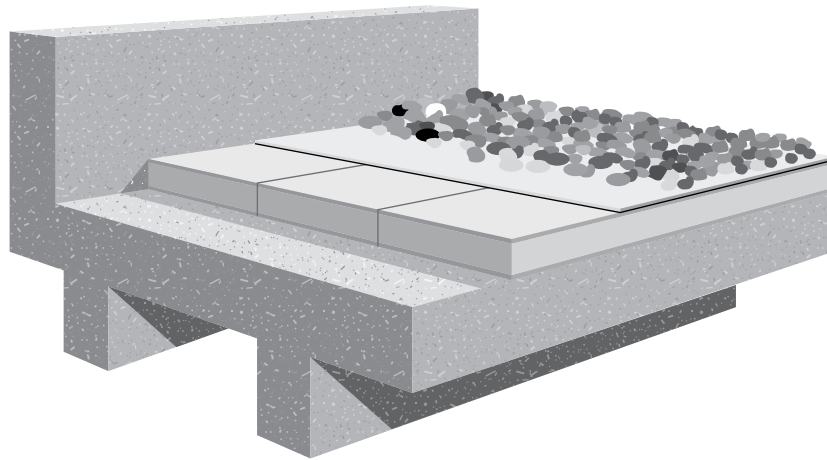

Fig. 1.1.1

The Firestone TPO Ballasted System is the most economical TPO Roofing System available and is suitable for a wide variety of buildings.

The TPO sheets are loose laid over an acceptable substrate. Rough substrates need to be isolated with an acceptable protective layer. Adjoining sheets are overlapped a minimum of 75 mm and the seams are heat-welded to form a continuous watertight membrane. Once the seams are welded and roof perimeters and penetrations are flashed in accordance with Firestone specifications, the TPO membrane is held in place using the following materials as ballast:

- Gravel, in the form of round, smooth, river washed aggregate without broken pieces, of adequate size (nominal 16 to 32 mm).
- Concrete pavers (min. 50 mm thickness) with smooth trowel finish. Installation of a protective mat is required.
- Crushed gravel that must be graduated, the larger the gravel, the higher the weight. A protective mat must be used.
- Poured in-situ concrete. A protective mat must be used.

The system features are:

- Use of large TPO panels up to 3.05 m.
- Fewer seams.
- Large choice of compatible substrates.
- Fast installation.
- Low installation cost.
- Excellent fire rating.
- Superb weathering resistance.

Prior to selection of this system, the specifier should evaluate structural conditions of the building to verify its load bearing capacity. Roof slopes and wind requirements should also be investigated.



## 1.2 Inverted System

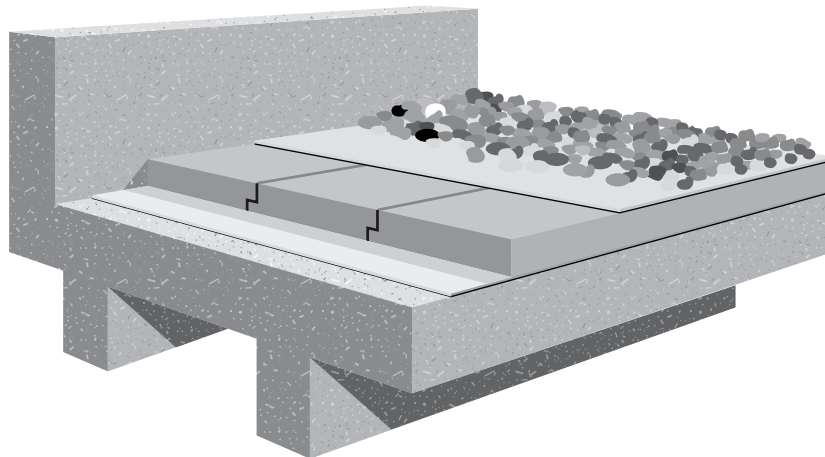

Fig. 1.2.1

The Firestone TPO Inverted System is a variation of the conventional ballasted system. It is ideal for roofs with regular traffic or in severe weather climates.

The TPO sheets are loose laid over an acceptable substrate. Rough substrates need to be isolated with an acceptable protective mat. Adjoining sheets are overlapped a minimum of 75 mm and heat-welded to form a continuous watertight membrane. Once the roof perimeters and penetrations are flashed in accordance with Firestone specifications, a layer of extruded polystyrene is placed over the membrane. A protective mat is then laid over the insulation and the total system is held in place using the following as ballast:

- Gravel, in the form of round, smooth, river washed aggregate without broken pieces of adequate size (nominal 16 to 32 mm).
- Concrete pavers (min. 50 mm thickness) with smooth trowel finish.
- Crushed gravel that must be graduated, the larger the gravel, the higher the weight.

The system features are :

- Use of large TPO panels up to 3.05 m.
- Fewer seams.
- Large choice of compatible substrates.
- Fast installation.
- Low installation cost.
- Extra durability.
- Flexibility for upgrading of insulation in reroofing projects.

Prior to selection of this system, the specifier should evaluate the structural conditions of the building with regard to its strength to accommodate the load. Roof slope, wind requirements and flashing height around details should also be investigated.

## 1.3 Mechanically Attached System

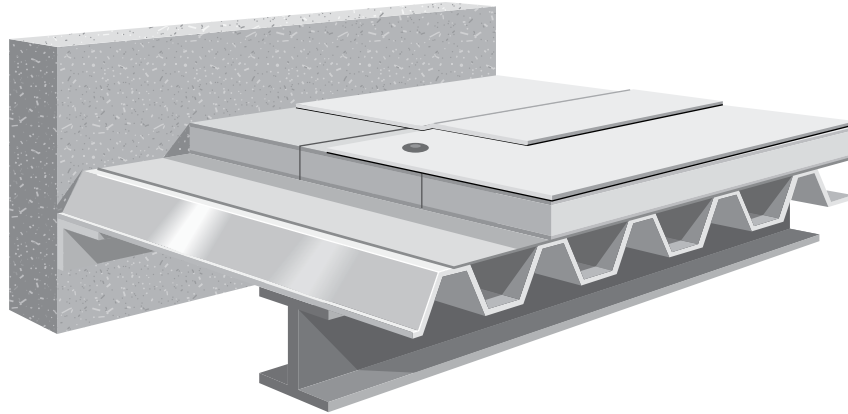

Fig. 1.3.1

The Firestone TPO Mechanically Attached System is a lightweight system, suitable for roofs that cannot carry the additional load of ballast, where the roof deck is suitable for mechanical attachment.

The system uses up to 2.44 m wide panels, which are loose laid over the substrate. Membrane panels are mechanically attached with plates and fasteners placed in the seams of adjoining sheets. The width of the membrane and spacing of the plates and fasteners differ to accommodate for wind loadings.

Adjoining sheets are overlapped at least 150 mm in case of a seam with mechanical anchoring and 75 mm in case of a seam without mechanical anchoring. The sheets are heat-welded to form a continuous, watertight membrane. All flashings around roof perimeters and penetrations are installed in accordance with Firestone details.

The system features are:

- Adaptable to unusual roof configurations.
- High wind uplift performance.
- Low material cost.
- Lightweight.

Prior to selection of this system, the specifier should evaluate the roof slope and determine whether the roof deck will provide sufficient pull-out resistance for the fastening system.



## 1.4 Fully Adhered System

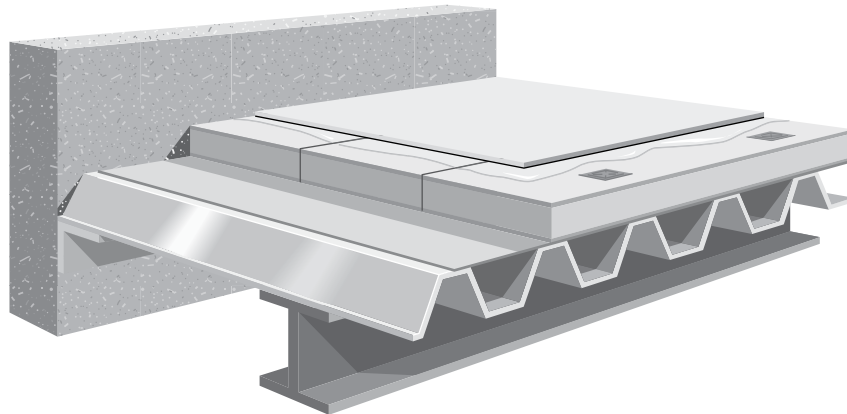

Fig. 1.4.1

The Firestone TPO Fully Adhered System is a lightweight system with outstanding design flexibility. It is suitable for contoured roofs, roofs with irregular shape and any roof with limited load bearing capacity, provided the substrate is compatible with adhesives.

The system typically uses up to 3.05 m wide panels, which are fully adhered directly to an acceptable substrate using Bonding Adhesive. Adjoining sheets are overlapped a minimum of 75 mm and the seams are heat-welded to form a continuous, watertight membrane. All flashings around roof perimeters and penetrations are installed in accordance with Firestone details.

The system features are:

- Applicable on any slope.
- Applicable to unusual roof configurations.
- Lightweight.
- High wind uplift performance.
- Aesthetics.

Prior to selection of this system, the specifier should determine whether the substrate is compatible with Bonding Adhesive to provide sufficient adhesion. For insulated roofs the ability of the roof deck to provide sufficient pull-out resistance for the fastening system should be established.